

ENG

**Prior to assembling this crib please follow these steps:**

- Read the instructions carefully and familiarize yourself with parts.
- Select a clean uncluttered area to open carton on.
- Carefully place all assembly hardware in box or other container to prevent losing parts while assembling.
- Assemble the furniture on the carton or carpet in order to protect the furniture finish and your floor.
- TO CLEAN CABINET: Wipe with a soft cotton cloth moistened with water.
- DO NOT USE ABRASIVES.
- DO NOT OVERTIGHTEN THE SCREWS
- It will be very helpful to have a friend assist you with assembly

ESP

**Siga las siguientes instrucciones para el montaje del gabinete:**

- Lea las instrucciones cuidadosamente y familiarice con las partes.
- Seleccione una area espaciosa en la cual pueda abrir el carton.
- Ponga todas las herramientas que necesitara para el montaje en alguna caja o receptaculo para prevenir la perdida de peizas de montaje.
- Ponga las peizas de madera encima del carton o alfombra, asi protegera tanto su piso como et gabinete.
- PARA LIMPIAR GABINETE: Pase un trapo de algodn medio humedo.
- NO USE ESTRAPAJO O NADA PARA RESTREGAR.

FRA

**Prenez connaissances de ces recommandations avant de débiter le montage du meuble:**

- Lisez attentivement les instructions et familiarisez-vous avec les différentes pièces.
- Choisissez un endroit avec suffisamment d' espace pour ouvrir la boîte et assembler le meuble.
- Placez les pièces d' assemblage dans un contenant ou à un endroit sûr afin d' éviter la perte de celles-ci.
- Assemblez votre meuble sur sa boîte d' emballage ou sur un tapis afin de protéger les pièces de votre et votre recouvrement de plancher.
- POUR NETTOYER LE MEUBLE: Essuyez avec un chiffon doux humecté d' eau.
- N'UTILISEZ PAS DE PRODUIT ABRASIF.

**Assembly Tools Required / Piezas requeridas para el montaje / Outils nécessaires au montage**

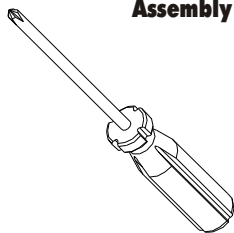

Phillips Head Screwdriver  
Destornillador de estrella  
Tournevis à pointe Phillips

STEP  
PASO  
ÉTAPE

7

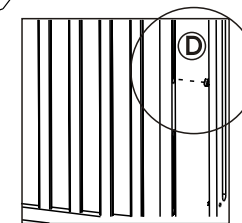
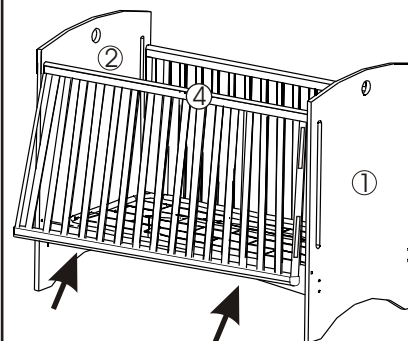

**! IMPORTANT !**  
Place the gate pin (D)  
into the bottom of the upper channel,  
lower the adjustable guard rail,  
and proceed to STEP 8

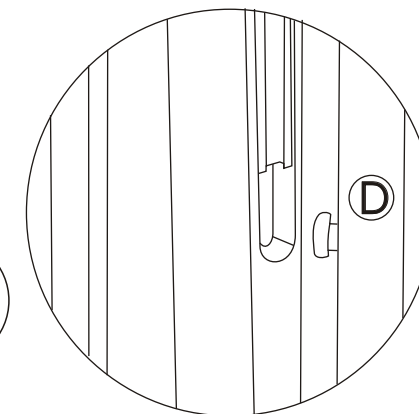

STEP  
PASO  
ÉTAPE

8

**!VERY IMPORTANT !**  
With the gate pin (D) in the upper channel, position the lower  
gate pin (E) into the lower channel and ease the gate  
down. Make sure all 4 gate pins (both D and E) are correctly  
inserted and tighten the screws (A)

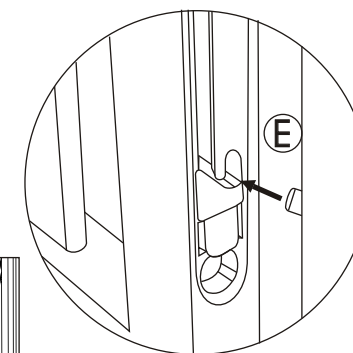
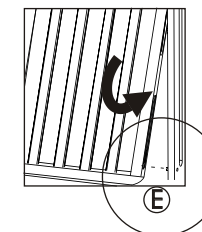
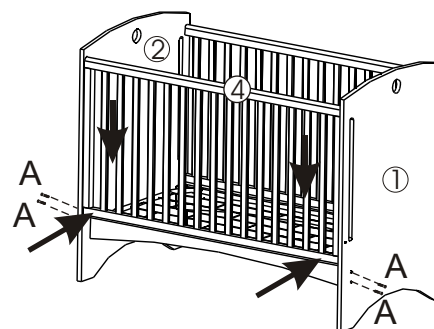



# WARNING



FAILURE TO FOLLOW THESE WARNINGS AND ASSEMBLY DIRECTIONS COULD RESULT IN SERIOUS INJURY OR DEATH

- READ ALL INSTRUCTIONS BEFORE ASSEMBLING CRIB. **KEEP INSTRUCTIONS FOR FUTURE USE.**
- BEFORE EACH USAGE OR ASSEMBLY, INSPECT CRIB FOR DAMAGED HARDWARE, LOOSE JOINTS, MISSING PARTS OR SHARP EDGES. DO NOT USE CRIB IF ANY PARTS ARE MISSING OR BROKEN. ASK YOUR DEALER OR WRITE TO **OFFI** FOR REPLACEMENT PARTS AND INSTRUCTIONAL LITERATURE IF NEEDED. DO NOT SUBSTITUTE PARTS.
- UPON COMPLETION OF ASSEMBLY, BE SURE ALL SCREWS AND BOLTS HAVE BEEN TIGHTENED SECURELY. A PERIODIC CHECK SHOULD BE MADE OF ALL SCREWS AND BOLTS AND RETIGHTEN IF NECESSARY.
- AFTER RAISING SIDE, MAKE SURE LATCHES ARE SECURED (BOTH SIDES!)
- WHEN CHILD IS ABLE TO CLIMB OUT OR REACHES THE HEIGHT OF 35 IN., THE CRIB SHALL NO LONGER BE USED.
- DO NOT PLACE CRIB NEAR WINDOW WHERE CORDS FROM BLINDS OR DRAPES MAY STRANGLE CHILD.
- IF REFINISHING, USE A NON-TOXIC FINISH SPECIFIED FOR CHILDREN'S PRODUCTS.
- DO NOT LEAVE CHILD IN CRIB WITH SIDE LOWERED. BE SURE SIDE IS IN RAISED AND IN THE LOCKED POSITION WHENEVER CHILD IS IN CRIB.
- WHEN CHILD IS ABLE TO PULL TO STANDING POSITION, SET MATTRESS TO LOWEST POSITION AND REMOVE BUMPER PADS, LARGE TOYS AND OTHER OBJECTS THAT COULD SERVE AS STEPS FOR CLIMBING OUT.
- NEVER USE PLASTIC SHIPPING BAGS OR OTHER PLASTIC FILM AS MATTRESS COVERS BECAUSE THEY CAN CAUSE SUFFOCATION.
- DO NOT USE A WATER MATTRESS WITH THIS CRIB.
- THE MATTRESS USED WITH THIS CRIB MUST BE AT LEAST 27 1/4 INCHES BY 51 5/8 INCHES WITH A THICKNESS NOT EXCEEDING 6". THE GAP BETWEEN THE MATTRESS AND THE SIDES OF THE CRIB SHOULD NOT EXCEED 1 1/2 INCHES WHEN THE MATTRESS IS PUSHED INTO THE CORNER OF THE CRIB.

**WARNING:** String cause strangulation! Do not place items with a string around child's neck, such as hood strings or pacifier cords. Do not suspend strings over crib or attach strings to toys.



## CR-10 Bebe Crib Ply

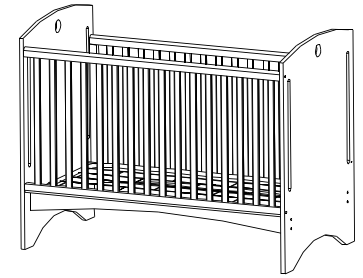

### ENG

Thank you for purchasing this **Offi** product. **Offi** is committed to customer satisfaction. Every effort has been made to ensure that your purchase is complete with quality components and simple instructions for assembly.

If you have any comments, questions or kind words, please call us at 1.800.958.offi (6334) or email to [info@offi.com](mailto:info@offi.com).

Find other **offi** products at [www.offi.com](http://www.offi.com)

### ESP

Gracias por comprar este producto de las **Offi**. **Offi** esta esta dedicada a la satisfaccion de sus clientes. Se ha hecho todo lo posible para garantizar que su compra de este producto este completo con un componente de calidad e instrucciones de montaje facil.

### FRA

Merci d'avoir acheté ce produit des **Offi**. **Offi** s'engage à satisfaire sa clientèle. Tous les efforts sant déployés pour 's assurer que le produit que vous avez acheté est complet et qu' il comporte des pièces de qualité et des instructions de montage simples.

STEP  
PASO  
ÉTAPE

5

**! IMPORTANT !**  
The adjustable metal mattress support (3) must be attached to the INSIDE of the stabilizer bar (6)

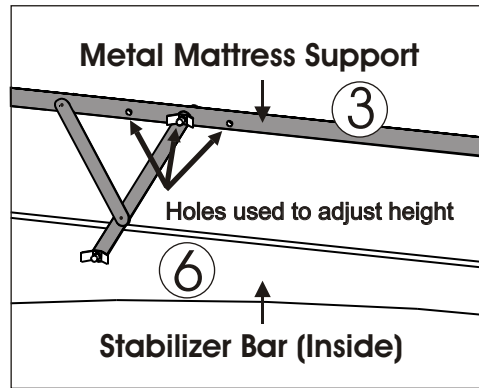
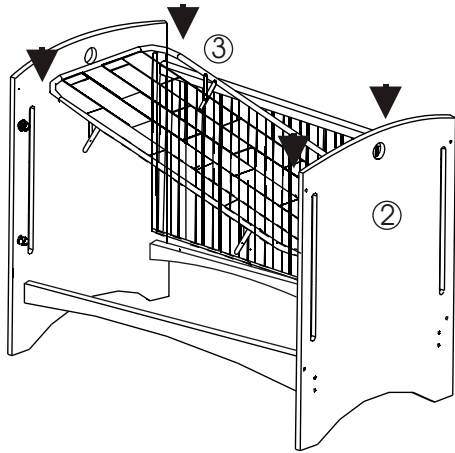

STEP  
PASO  
ÉTAPE

6

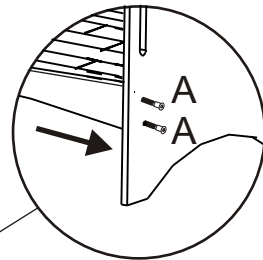
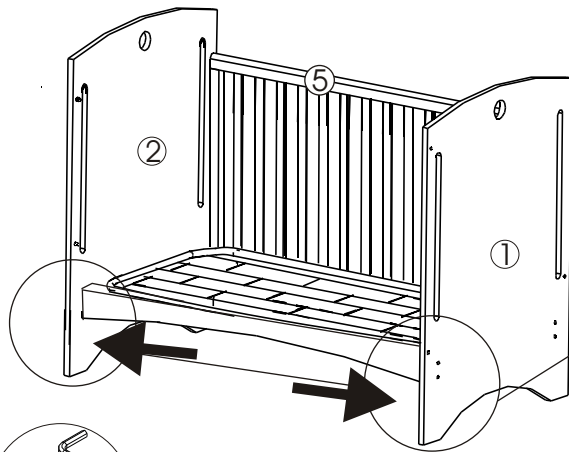

**! IMPORTANT !**  
Loosen the screws on the headboard (1) and foot board (2) and open (1/2 inch) before placing the adjustable guard rail (4)

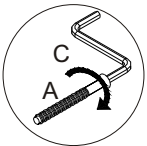

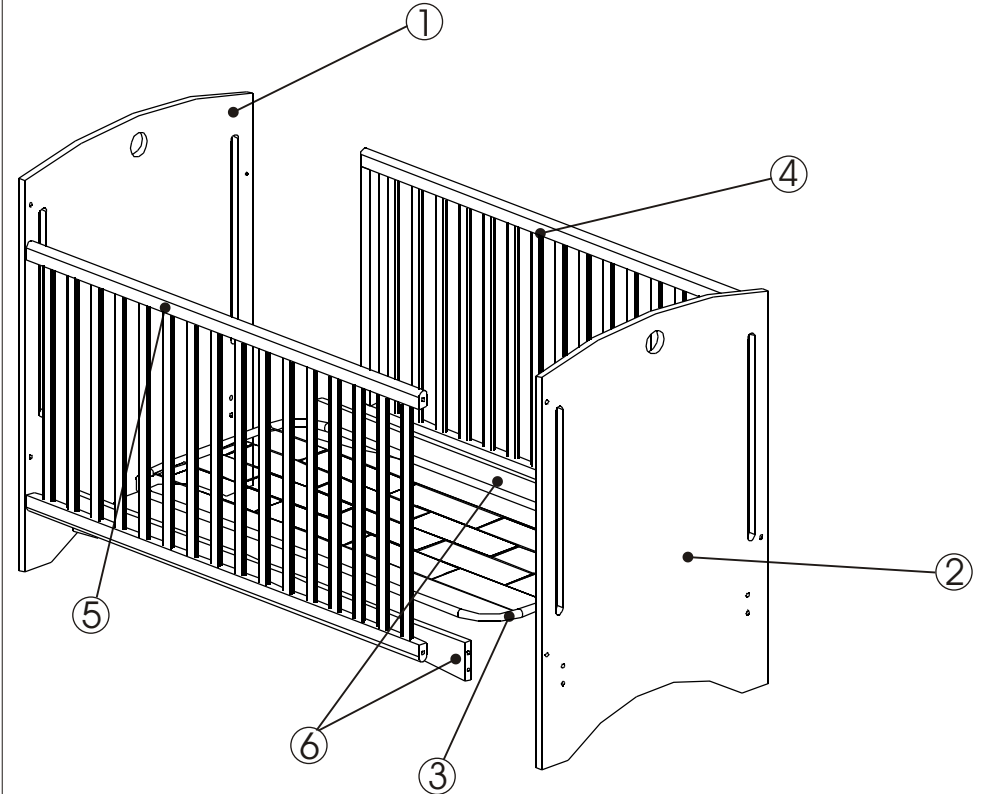

**PARTS LIST / LISTA DE PARTES / LISTE DE PIÈCES**



**PARTS LIST  
LISTA DE PARTES  
LISTE DES PIÈCES**

**HARDWARE  
HERRAJE  
QUINCAILLERIE**

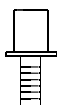
CODE CODIGO CODE	QTY. CAND. Qté.	DESCRIPTION DESCRIPCION DESCRIPTION	A 12 pcs	C 1 pc
1	01	HEAD BOARD		
2	01	FOOTBOARD		
3	01	ADJUSTABLE METAL MATTRESS SUPPORT (Includes 8 bolts and wing nuts)		
4	01	ADJUSTABLE GUARD RAIL	D 2 pcs	E 2 pcs
5	01	FIXED GUARD RAIL		
6	02	STABILIZER BAR		

STEP  
PASO  
ÉTAPE

1

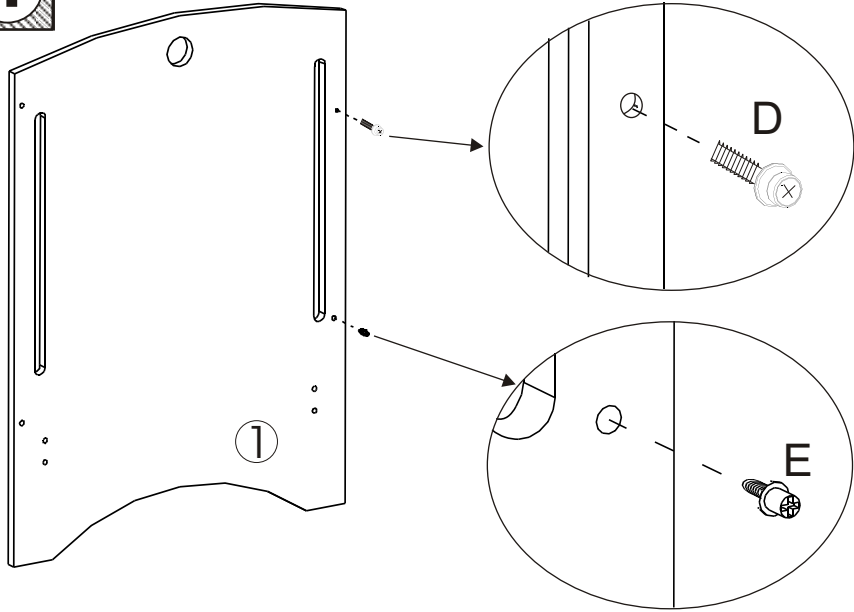

STEP  
PASO  
ÉTAPE

2

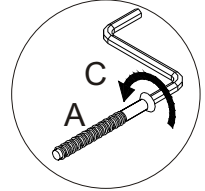
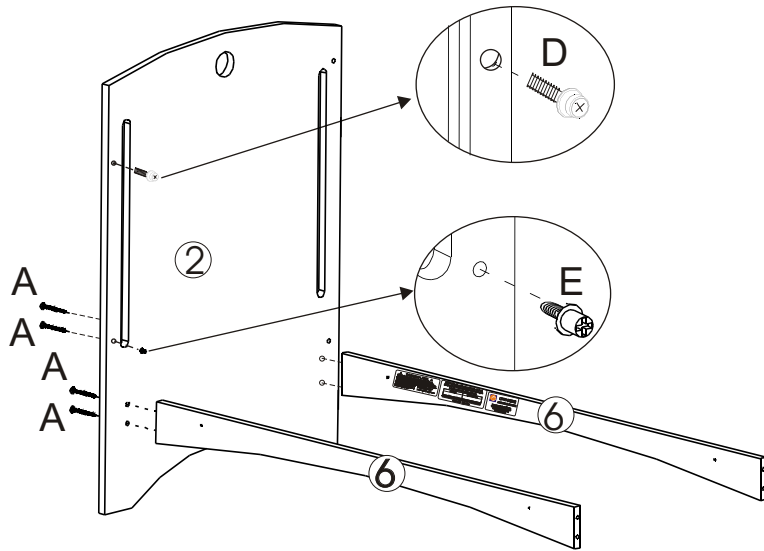

STEP  
PASO  
ÉTAPE

3

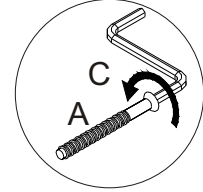
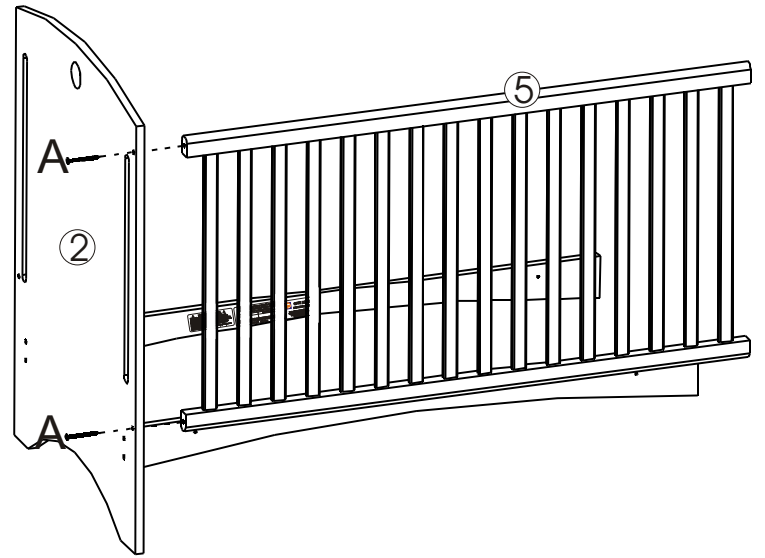

STEP  
PASO  
ÉTAPE

4

